



Designation: C186 – 17

Standard Test Method for Heat of Hydration of Hydraulic Cement¹

This standard is issued under the fixed designation C186; the number immediately following the designation indicates the year of original adoption or, in the case of revision, the year of last revision. A number in parentheses indicates the year of last reapproval. A superscript epsilon (ϵ) indicates an editorial change since the last revision or reapproval.

1. Scope*

1.1 This test method covers the determination of the heat of hydration of a hydraulic cement by measuring the heat of solution of the dry cement and the heat of solution of a separate portion of the cement that has been partially hydrated for 7 and for 28 days, the difference between these values being the heat of hydration for the respective hydrating period.

1.2 The results of this test method may be inaccurate if some of the components of the hydraulic cement are insoluble in the nitric acid/hydrofluoric acid solution.

1.3 The values stated in SI units are to be regarded as standard. No other units of measurement are included in this standard.

1.4 Values in SI units shall be obtained by measurement in SI units or by appropriate conversion, using the Rules for Conversion and Rounding given in Standard [IEEE/ASTM SI 10](#), or measurements made in other units.

1.5 *This standard does not purport to address all of the safety concerns, if any, associated with its use. It is the responsibility of the user of this standard to establish appropriate safety, health, and environmental practices and determine the applicability of regulatory limitations prior to use.*
Warning—*Fresh hydraulic cementitious mixtures are caustic and may cause chemical burns to skin and tissue upon prolonged exposure.*²

1.6 *This international standard was developed in accordance with internationally recognized principles on standardization established in the Decision on Principles for the Development of International Standards, Guides and Recommendations issued by the World Trade Organization Technical Barriers to Trade (TBT) Committee.*

¹ This test method is under the jurisdiction of ASTM Committee C01 on Cement and is the direct responsibility of Subcommittee C01.26 on Heat of Hydration.

Current edition approved Oct. 1, 2017. Published November 2017. Originally approved in 1944. Last previous edition approved in 2015 as C186 – 15a. DOI: 10.1520/C0186-17.

² Section on Safety, Manual of Cement Testing, *Annual Book of ASTM Standards*, Vol 04.01.

2. Referenced Documents

2.1 *ASTM Standards*:³

[C109/C109M Test Method for Compressive Strength of Hydraulic Cement Mortars \(Using 2-in. or \[50-mm\] Cube Specimens\)](#)

[C114 Test Methods for Chemical Analysis of Hydraulic Cement](#)

[C670 Practice for Preparing Precision and Bias Statements for Test Methods for Construction Materials](#)

[C1005 Specification for Reference Masses and Devices for Determining Mass and Volume for Use in the Physical Testing of Hydraulic Cements](#)

[E11 Specification for Woven Wire Test Sieve Cloth and Test Sieves](#)

[IEEE/ASTM SI 10 Standard for Use of the International System of Units \(SI\): The Modern Metric System](#)

3. Significance and Use

3.1 The purpose of this test is to determine if the hydraulic cement under test meets the heat of hydration requirement of the applicable hydraulic cement specification.

3.2 This test may also be used for research purposes when it is desired to determine the heat of hydration of hydraulic cement at any age.

NOTE 1—When tests are performed for research purposes, useful additional information can be obtained by determining fineness, chemical and compound compositions.

3.3 Determination of the heat of hydration of hydraulic cements provides information that is helpful for calculating temperature rise in mass concrete.

4. Apparatus

4.1 *Calorimetric Apparatus*:

4.1.1 *Calorimeter*—The calorimeter, such as that illustrated in [Fig. 1](#), shall consist of a 0.5 L, wide-mouth vacuum jar, with

³ For referenced ASTM standards, visit the ASTM website, www.astm.org, or contact ASTM Customer Service at service@astm.org. For *Annual Book of ASTM Standards* volume information, refer to the standard's Document Summary page on the ASTM website.

*A Summary of Changes section appears at the end of this standard

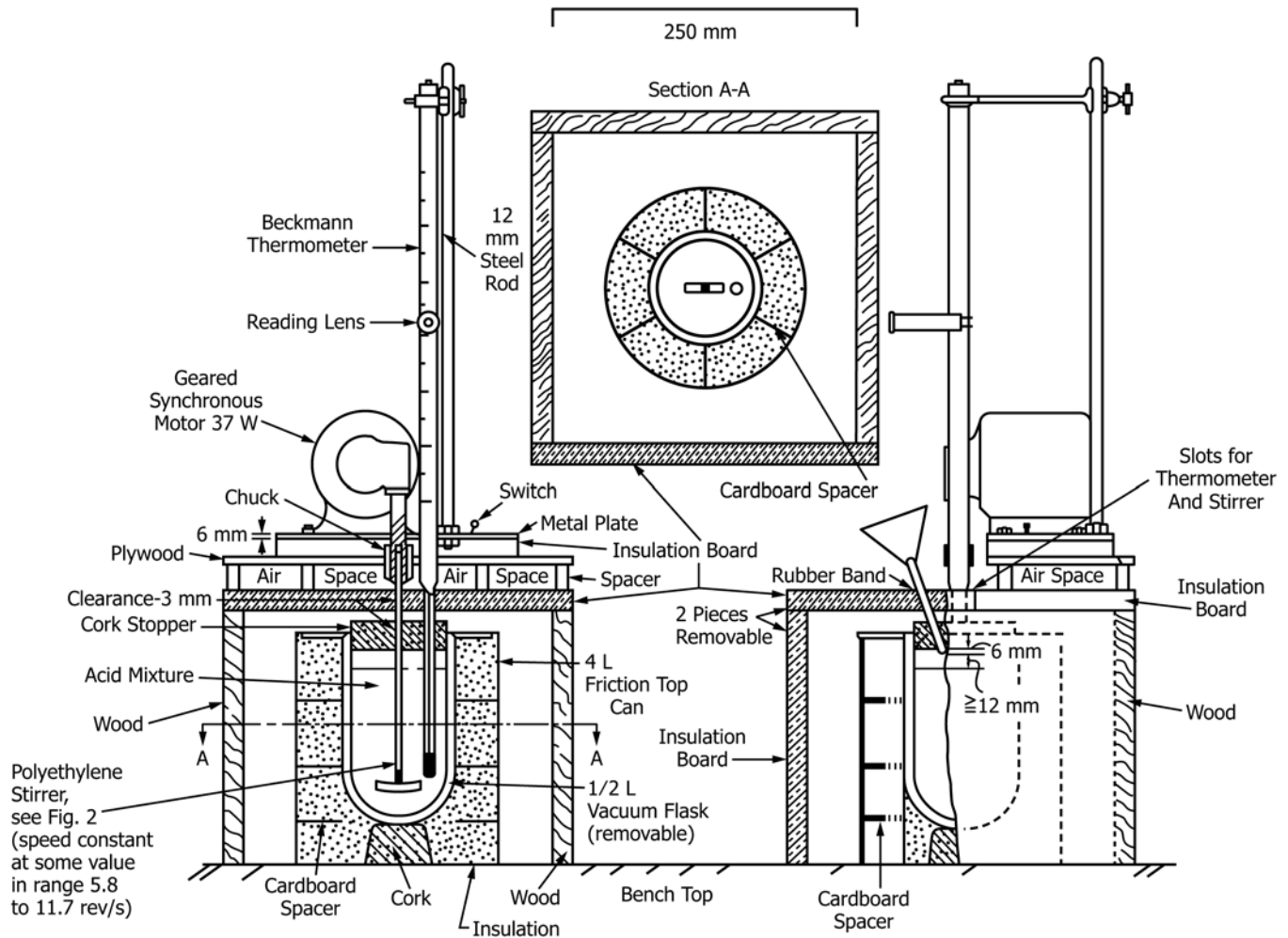

FIG. 1 Calorimeter

cork stopper, or other suitable non-reactive stopper held in a suitably insulated container (see 4.1.2) to keep the vacuum jar in position and to protect the jar from undue temperature fluctuations. The vacuum jar shall be coated on the interior with a material resistant to hydrofluoric acid, such as a baked phenolic resin, a baked vinyl chloride acetate resin, or beeswax. The acid-resistant coating shall be intact and free of cracks at all times; it shall be examined frequently and renewed whenever necessary. As another means of protecting the vacuum jar, a plastic liner of suitable size may be used instead of coating the interior of the jar. The contents of the vacuum jar shall not change more than 0.001°C/min per degree difference from room temperature when filled with 425 g of the acid specified in 6.2, stoppered, and allowed to stand unstirred for 30 min. The temperature for this check shall approximate the starting temperatures to be used in making the determination.

4.1.2 *Insulated Container*—The container shall have an insulating layer of a material such as non-reactive foam, cotton, or fiber-glass, which shall be at least 25 mm in thickness and shall encase the sides and bottom of the vacuum jar, but shall be so arranged as to permit easy removal of the jar.

4.1.3 *Thermometers*—Two thermometers are required. One is a high-precision thermometer required to determine temperature rise associated with dissolution of cement during determinations. For purposes of this test method, this thermometer is called the *solution thermometer*. The other thermometer is used for measuring sample temperature before introduction into the calorimeter and air temperature during the determination. For purposes of this test method, it is called the *reference thermometer*.

4.1.3.1 *Solution thermometer*—The solution thermometer shall be readable to 0.001°C and have an accuracy of 0.1°C. The solution thermometer may be either a Beckman type (see Note 2), which is a mercury-in-glass type that only outputs temperature differentials, or a digital type that gives actual temperature outputs. If a Beckman type is used, it shall be graduated to at least 0.01°C, with readings to 0.001°C that can be estimated by interpolation between these graduations. It shall also have a temperature range of at least 6°C.

NOTE 2— If the part of the thermometer that will be in contact with the test solution is sensitive to the nitric and hydrofluoric acids in the test solution, then it is recommended that this part of the thermometer be

coated with a resistant material to prolong the service life of the thermometer.

4.1.3.2 *Reference thermometer*—The reference thermometer shall be readable to 0.1°C and have an accuracy of 1°C (Note 3).

NOTE 3—Research Report No. C01-1014⁴ contains an analysis supporting the readability and accuracy requirements of thermometers.

4.1.4 *Funnel*—The funnel through which the sample is introduced into the calorimeter shall be glass or plastic and shall have a stem inside diameter of at least 6 mm (see Note 4).

NOTE 4—The minimum diameter is to prevent clogging of the powdered cement sample. The length of the stem will need to be adjusted so that the sample is delivered without the tip becoming wet from the acid solution, which will cause the funnel to become clogged and necessitate aborting the determination. The angle of the stem will need to be adjusted so that sample is not delivered onto the rotating stirrer, which will cause sample to cake at the liquid line.

4.1.5 *Stirring Assembly*—The stirrer shall be a three-bladed polyethylene propeller having the dimensions shown in Fig. 2, and shall extend as closely as possible to the bottom of the calorimeter. The motor shall be of the constant-speed type, at least 37 W, and shall be equipped with a geared speed reducer so that one speed, in the range of 5.8 to 11.7 rev/s, can be maintained constant.

NOTE 5—The stirrer shown in Fig. 2 may be readily made from a commercially available three-bladed polyethylene propeller having a propeller diameter of 34 mm, shaft diameter of 6 mm, and a shaft length of approximately 455 mm. The function of the stirrer is two-fold: to

maintain uniform temperature throughout the liquid, and to supply sufficient agitation to keep the solid in suspension in the acid mixture. Since a stirrer capable of keeping the solid in suspension generates considerable heat in the calorimeter, it is important that the stirrer speed and, hence the rate of heat generation, be maintained constant. Because such constancy is difficult to achieve with other types of motors, a synchronous motor with a geared speed reducer is recommended.

4.2 *Mixer*—A moderate-speed mechanical mixer, such as a milk-shake type stirrer, capable of intimately mixing the cement and water to a uniform paste.

4.3 *Storage*—Storage space with temperature controlled at $23.0 \pm 2.0^\circ\text{C}$.

4.4 *Mortar*, approximately 200 mm in diameter, and pestle for grinding the partially hydrated samples.

4.5 *Drying Oven*, maintained at 100 to 110°C.

4.6 *Sieves*, 150 μm (No. 100) and 850 μm (No. 20), conforming to Specification E11.

4.7 *Crucibles*, platinum, 30 mL capacity, with covers, for loss on ignition determination.

4.8 *Muffle Furnace*, or suitable burners capable of maintaining a temperature of 900 to 950°C.

4.9 *Analytical Balance and Analytical Weights*, conforming to the requirements prescribed in Test Methods C114 for weighing out calorimetric samples and for loss on ignition weighings.

4.10 *Weights and Weighing Devices*, conforming to the requirements of Specification C1005. The weighing device shall be evaluated at a total load of 1000 g.

⁴ Supporting data have been filed at ASTM International Headquarters and may be obtained by requesting Research Report RR:C01-1014. Contact ASTM Customer Service at service@astm.org.

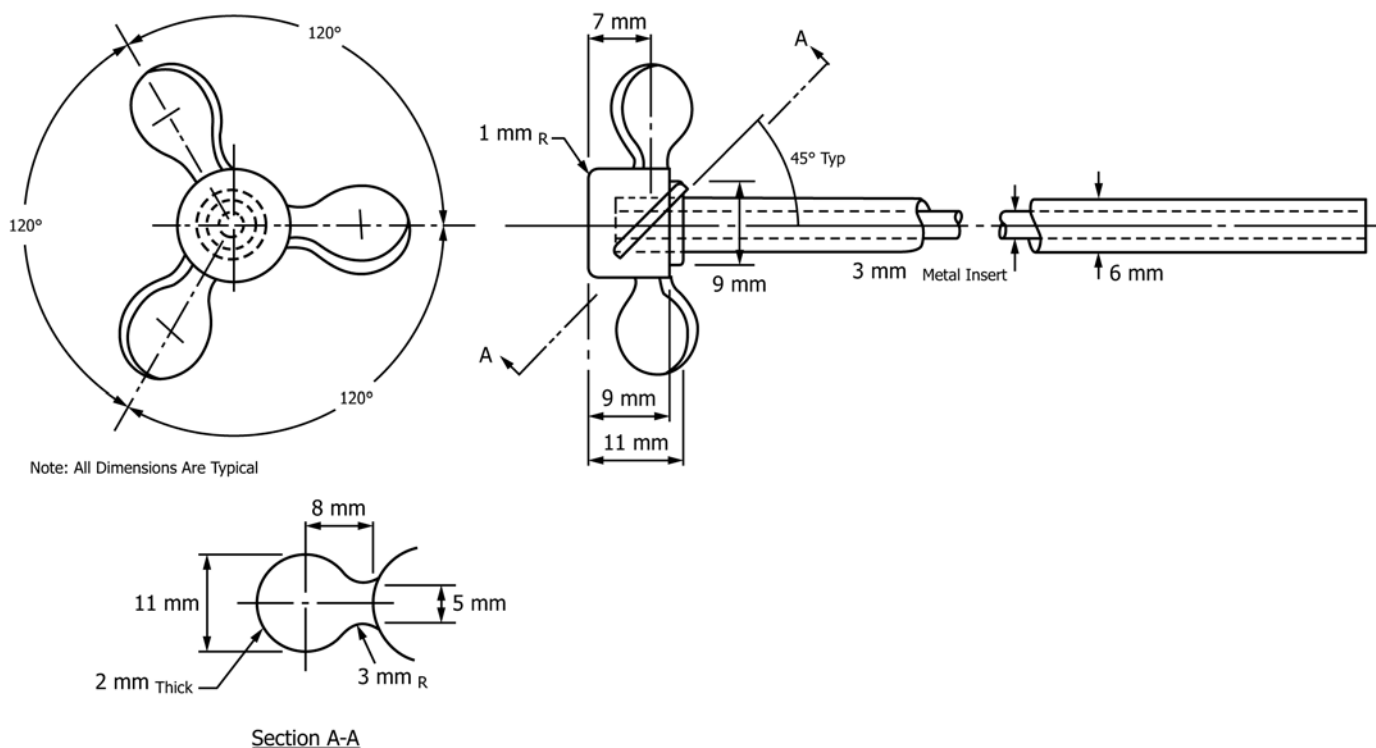

FIG. 2 Stirrer